



Shopfitters by passion

vizona

Technical instruction

Technical instruction

August 2024

Jeep®

Jeep Big Visual Showroom (H285 L230)

- **ST-I-JP02A-H**



Dimensions : 2300x45x2850

Weight : 20 Kg

Electrical connection : None

Mounting position : Wall



Jeep Big Visual Showroom (H285 L230)

Requirements before installation

- The area must be accessible with a pallet truck (or equivalent).
- The wall must be reinforced according to the weight specification of the article.

to observe

- The mounting height follows the CIB FIAT ABARTH

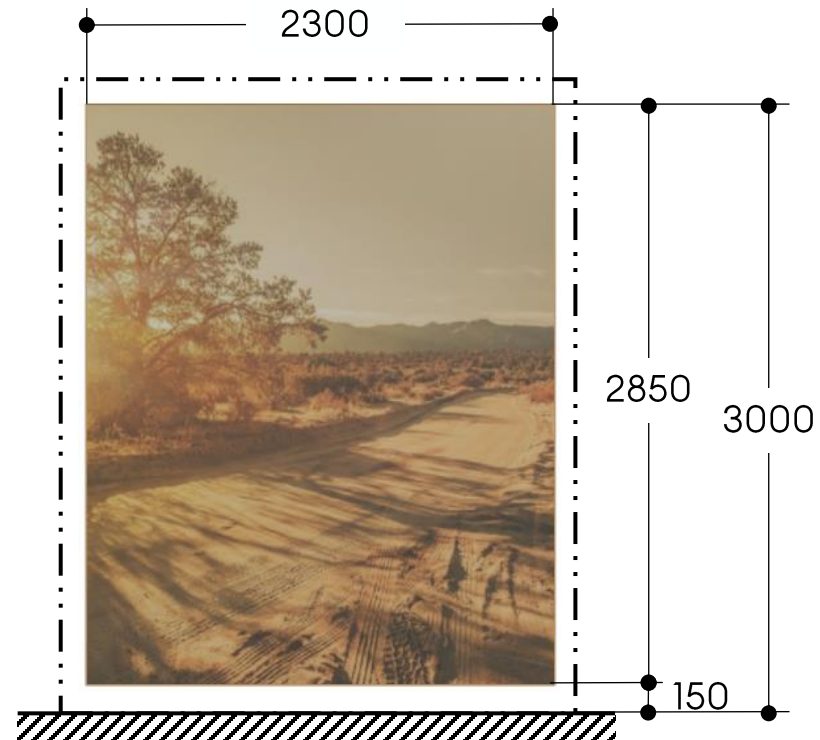

Explanation of symbols

 Wall reinforcement

Jeep Big Visual Showroom (H270 L218)

- **ST-I-JP02A**



Dimensions : 2180x45x2700

Weight : 18 Kg

Electrical connection : None

Mounting position : Wall



Jeep Big Visual Showroom (H270 L218)

Requirements before installation

- The area must be accessible with a pallet truck (or equivalent).
- The wall must be reinforced according to the weight specification of the article.

to observe

- The mounting height follows the CIB FIAT ABARTH

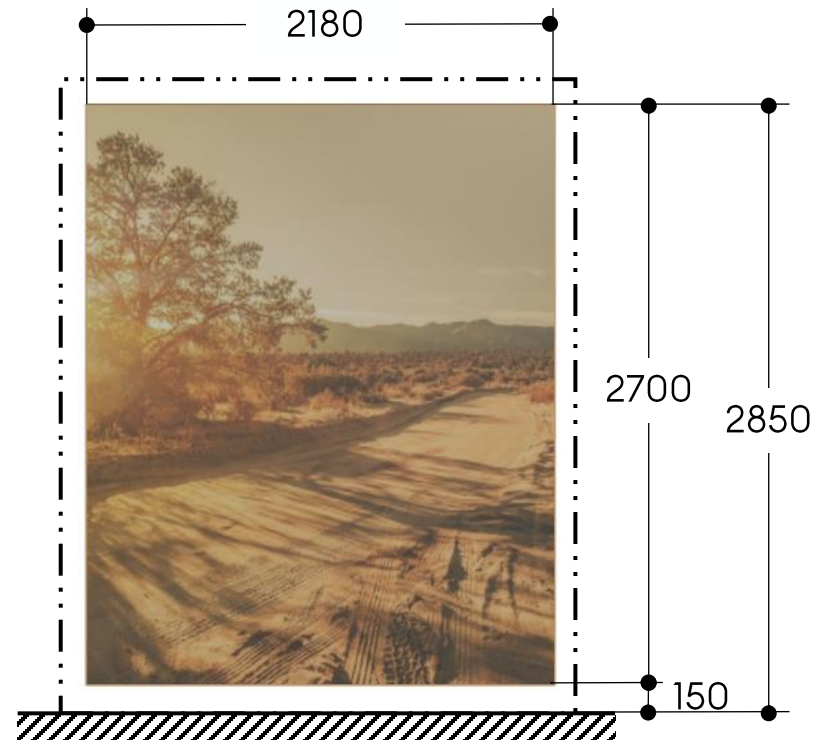

Explanation of symbols

 Wall reinforcement

Seven Slot Grille (small version)

- **ST-I-JP03C**
- **8005116**

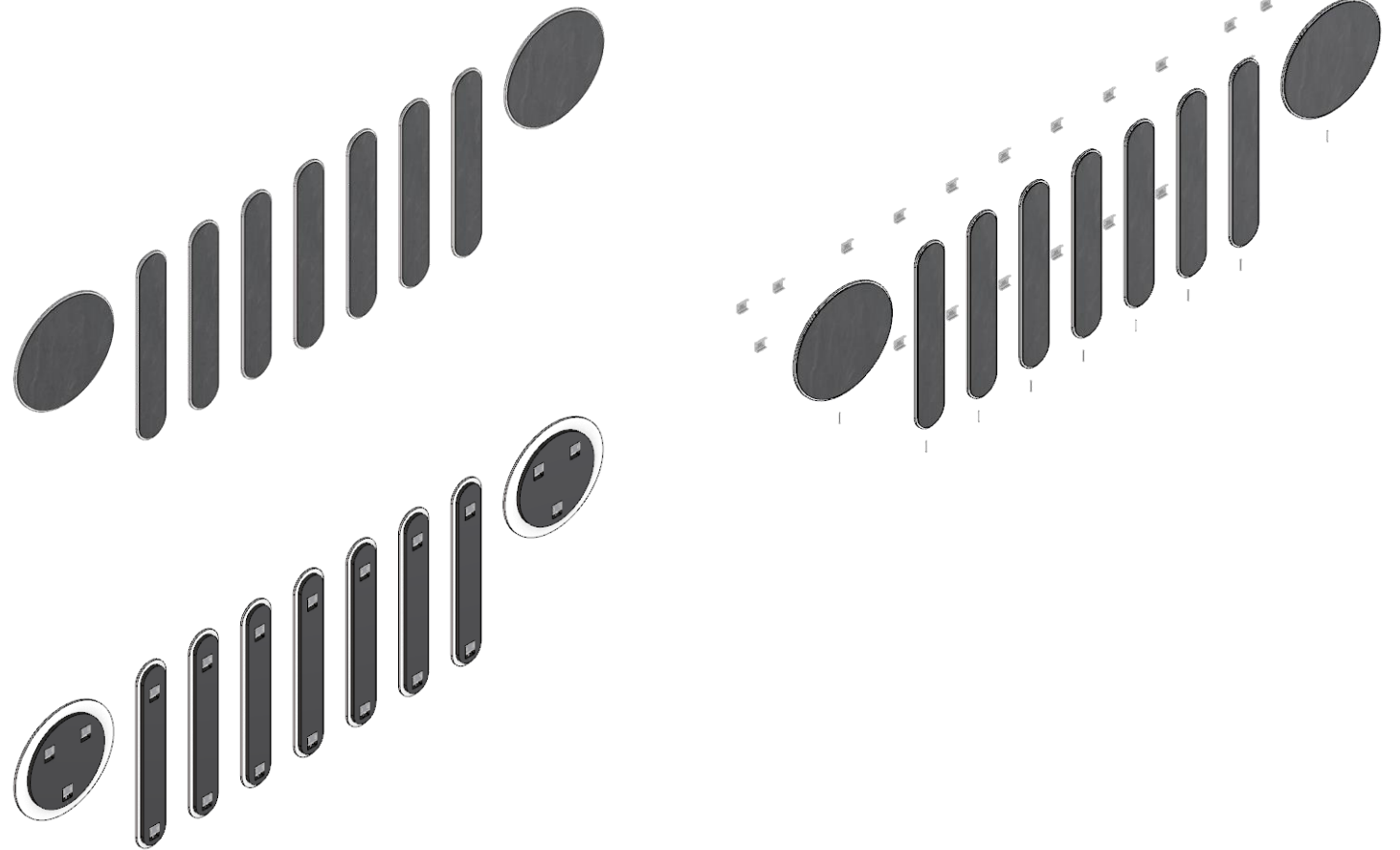

Dimensions : 3800x1062x35
Weight : 50 Kg
Electrical connection : None
Mounting position : Wall

Seven Slot Grille (small version)

Requirements before installation

- The area must be accessible with a pallet truck (or equivalent).
- The wall must be reinforced according to the weight specification of the article.

to observe

- The mounting height follows the CIB FIAT ABARTH

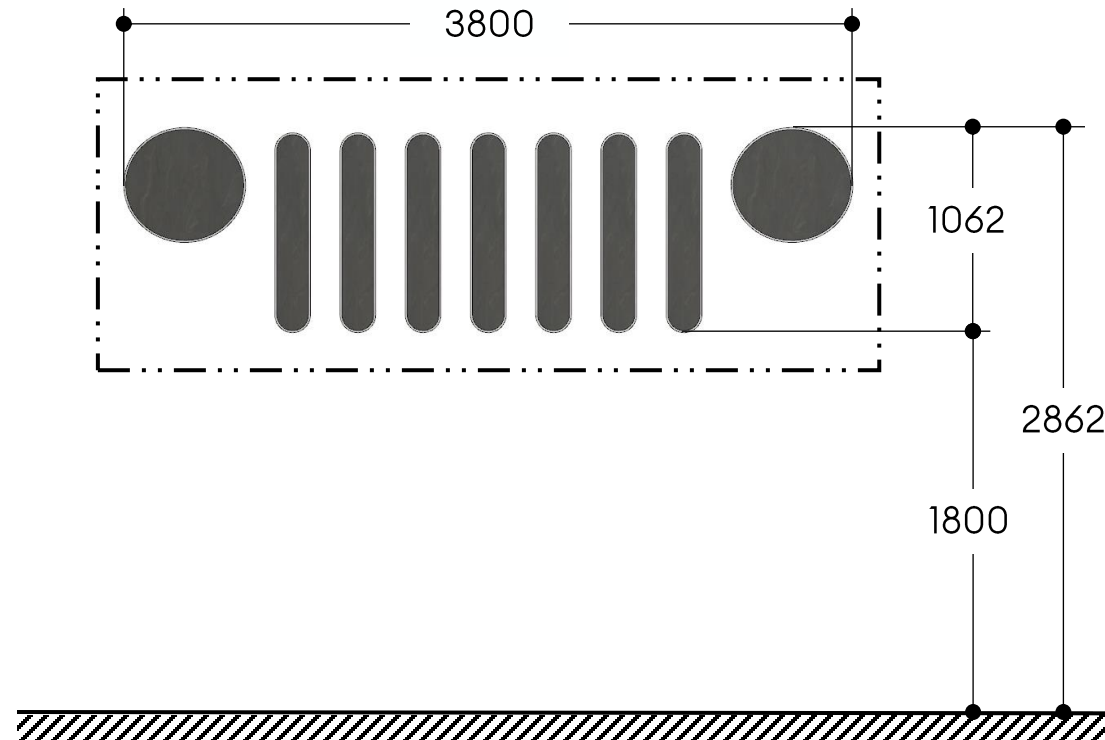

Explanation of symbols

 Wall reinforcement

Seven Slot Grille (large version)

- **ST-I-JPTBC**
- **8005117**

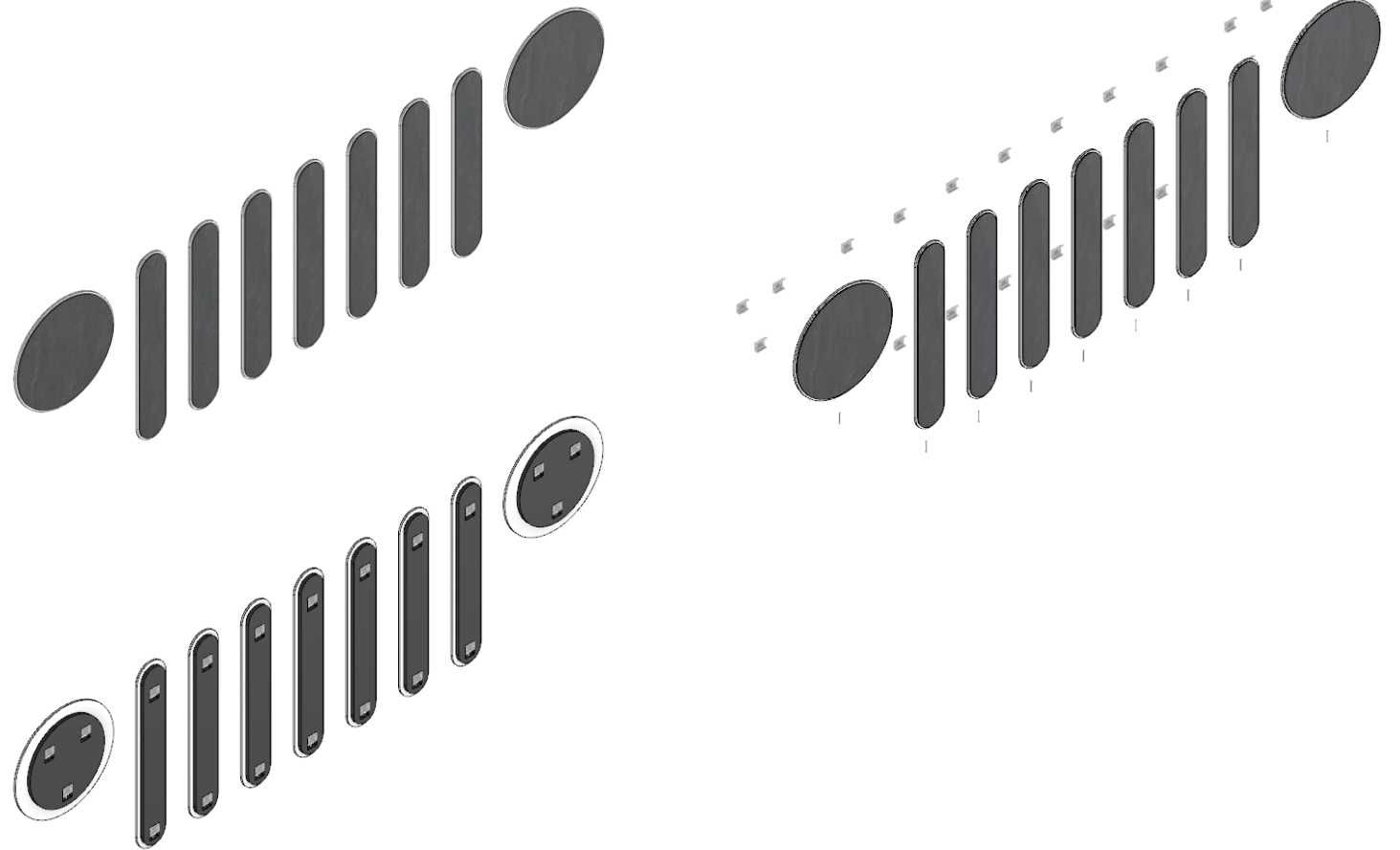

Dimensions : 6000x1677x35

Weight : 130 Kg

Electrical connection : None

Mounting position : Wall

Seven Slot Grille (large version)

Requirements before installation

- The area must be accessible with a pallet truck (or equivalent).
- The wall must be reinforced according to the weight specification of the article.

to observe

- The mounting height follows the CIB FIAT ABARTH

Explanation of symbols

 Wall reinforcement

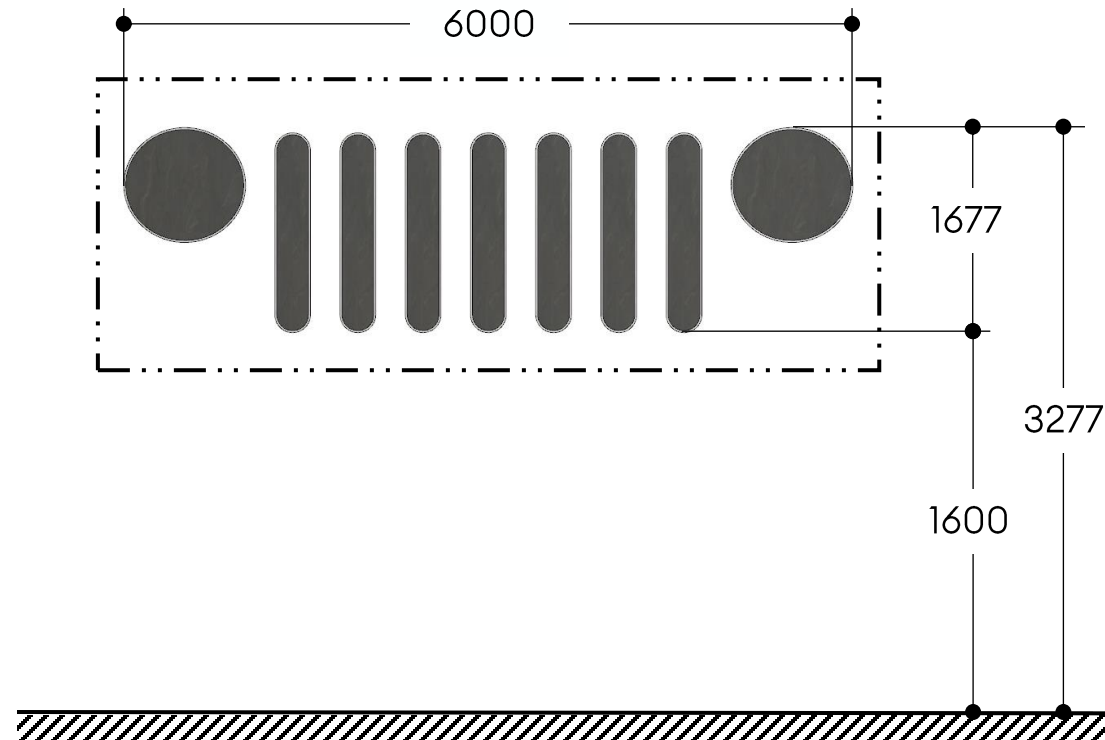

Wallmounted 4xe Panel

- ST-I-JP03E
- 8005944

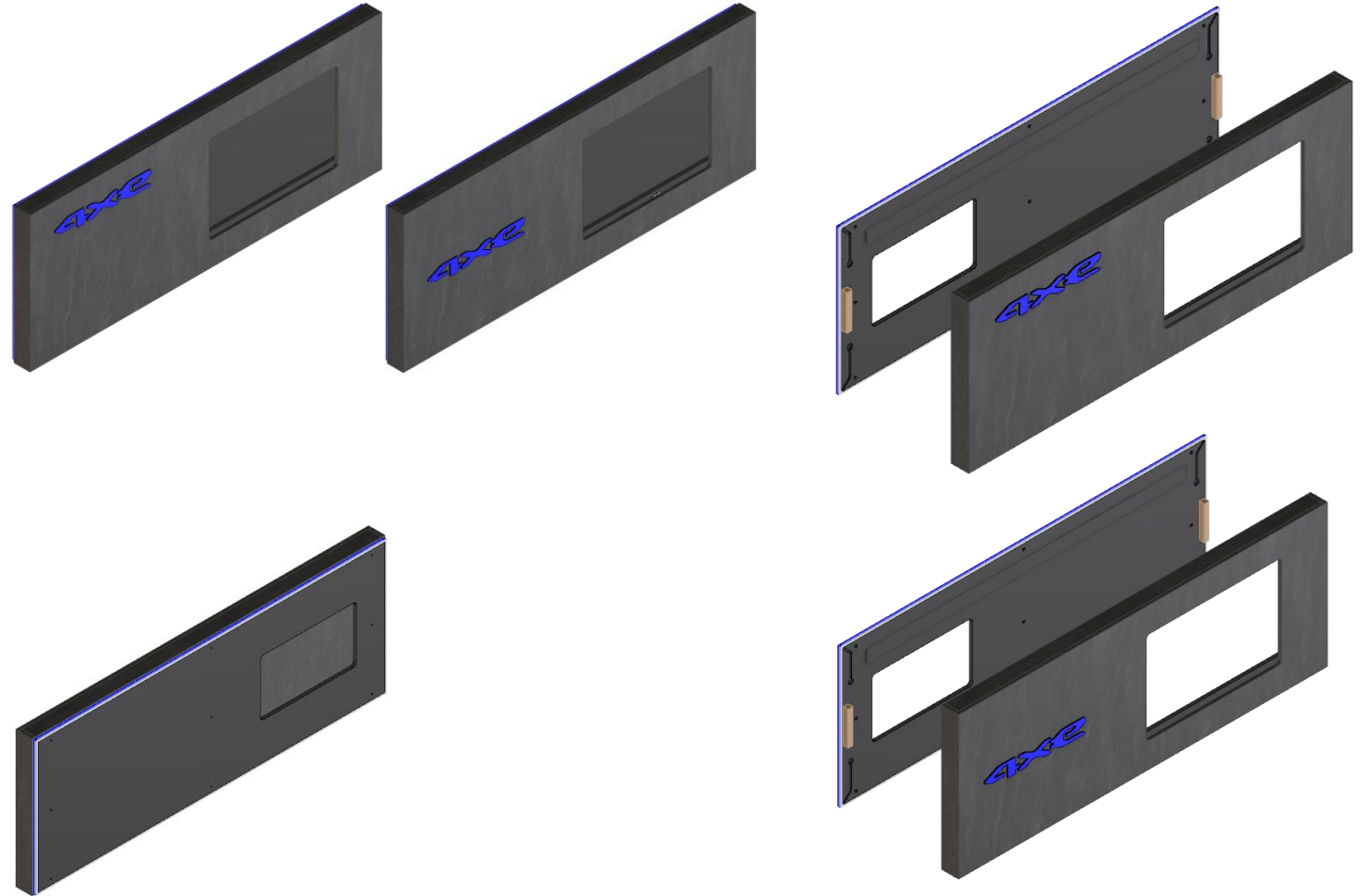

Dimensions : 2200x120x850
Weight : 65 Kg
Electrical connection : 230V
Mounting position : Wall

Wallmounted 4xe Panel



Requirements before installation

- The area must be accessible with a pallet truck (or equivalent).
- The wall must be reinforced according to the weight specification of the article.

to observe

- The wall and the substructure must be made of a suitable material to support the unit.
- Monitor, monitor holder and recharge box are not included in the scope of delivery.

Explanation of symbols

-  Wall reinforcement
-  Inspection panel / power supply
-  Wall socket

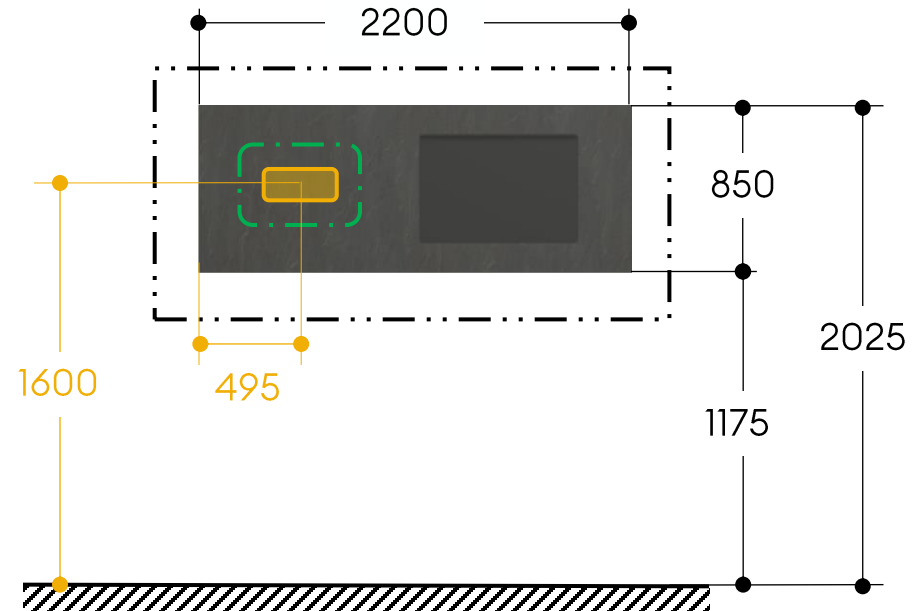

Freestanding 4xe Panel

- ST-I-JP **TBC**
- 8010999

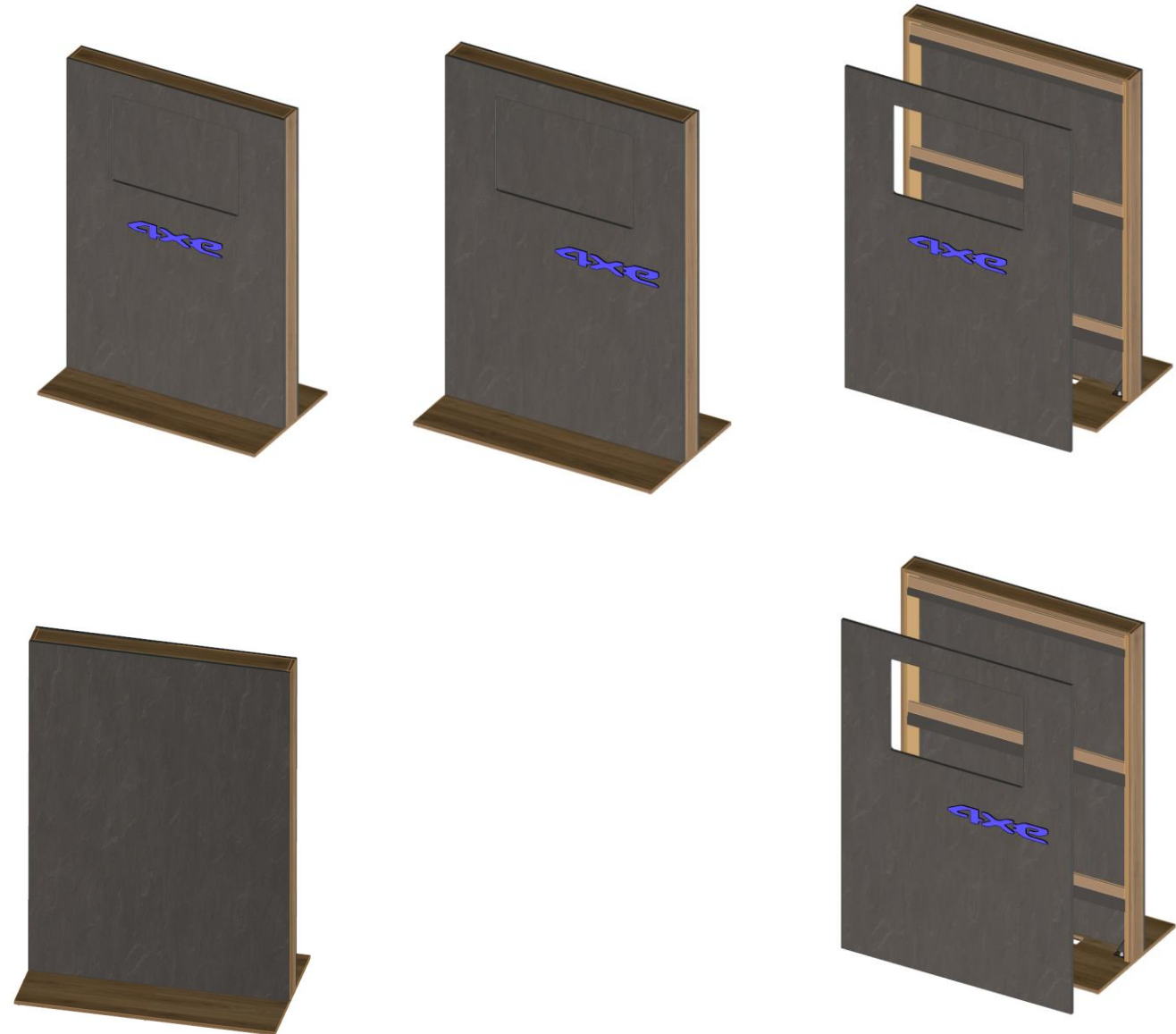

Dimensions :1380x800x2000
Weight : 160 Kg
Electrical connection : 230V
Mounting position : Middle space

Wallmounted 4xe Panel

Requirements before installation

- The area must be accessible with a pallet truck (or equivalent).

to observe

- Monitor, monitor holder and recharge box are not included in the scope of delivery.

Explanation of symbols

-  Inspection panel / power supply
-  Floor socket

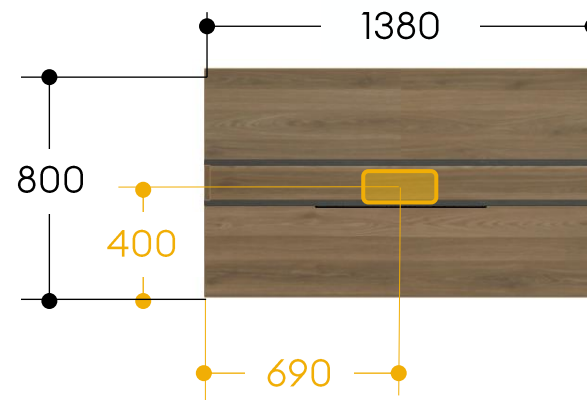
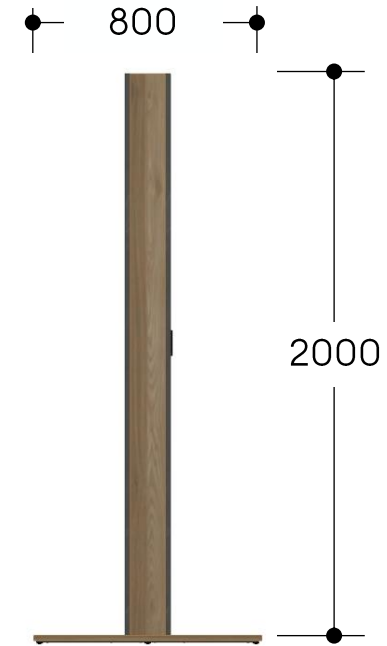

Sales Desk Left

- **ST-I-JP04A2**
- **8005380**



Dimensions :2000x1900x750

Weight : 115 Kg

Electrical connection : 230V

Mounting position : Middle space

Sales Desk Left

Requirements before installation

- The area must be accessible with a pallet truck (or equivalent).

to observe

- Supply cable, power strip etc. are not included in the scope of delivery.

Explanation of symbols

 Inspection panel / power supply

 Floor socket

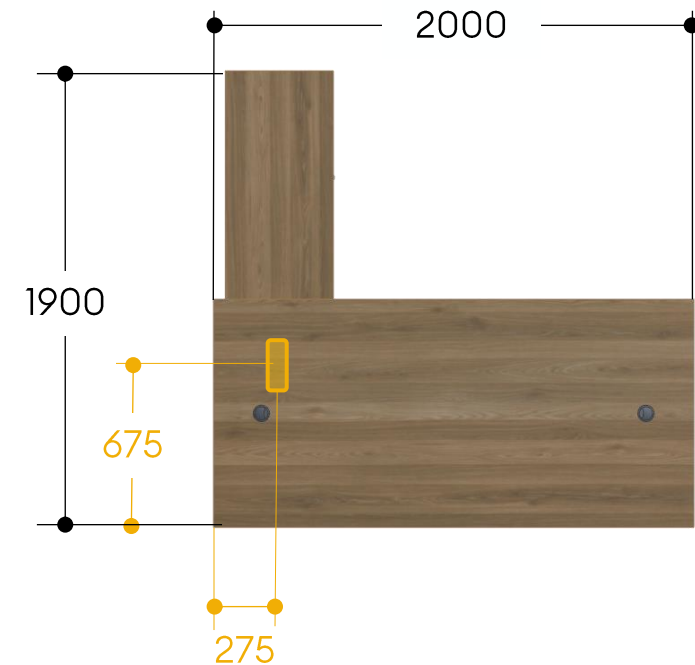
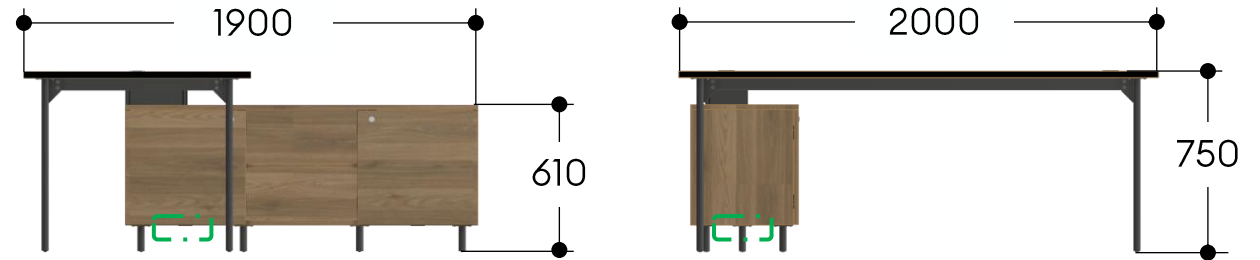

Sales Desk Right

- **ST-I-JP04A1**
- **8008296**



Dimensions :2000x1900x750

Weight : 115 Kg

Electrical connection : 230V

Mounting position : Middle space

Sales Desk Right

Requirements before installation

- The area must be accessible with a pallet truck (or equivalent).

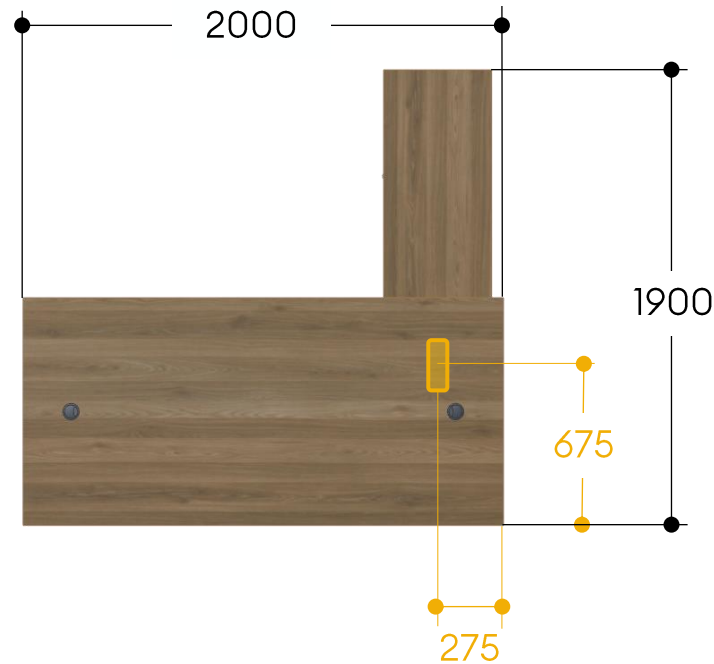
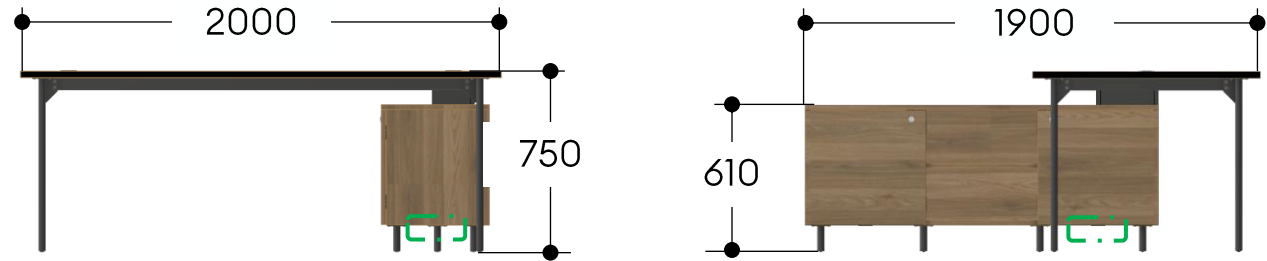

to observe

- Supply cable, power strip etc. are not included in the scope of delivery.

Explanation of symbols

 Inspection panel / power supply

 Floor socket

Jeep Big Visual Sales Station (H280 L230)

- **ST-I-JP4G-H**
- **8005466**



Dimensions : 2300x45x2850
Weight : 20 Kg
Electrical connection : None
Mounting position : Wall

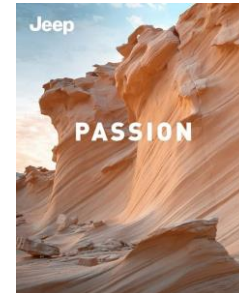
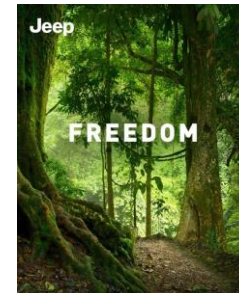

Jeep Big Visual Sales Station (H280 L230)

Requirements before installation



- The area must be accessible with a pallet truck (or equivalent).
- The wall must be reinforced according to the weight specification of the article.

to observe

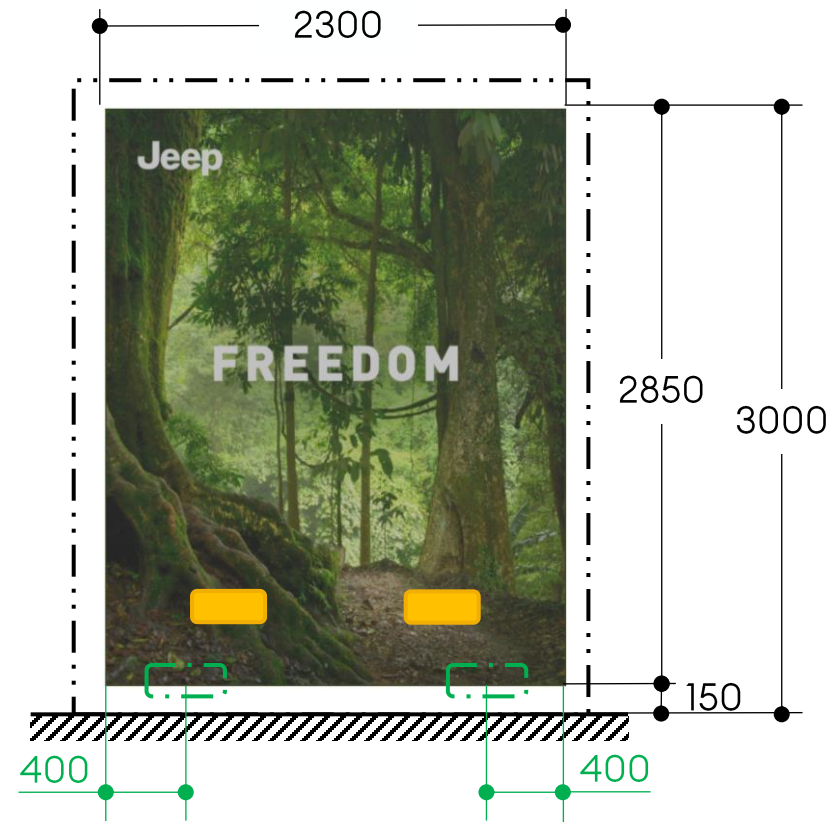
- The wall and the substructure must be made of a suitable material to support the unit.
- Supply cable, power strip etc. are not included in the scope of delivery.

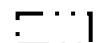

Explanation of symbols

-  Wall reinforcement
-  Inspection panel / power supply
-  Wall socket (2 options)

Jeep Big Visual Sales Station (H270 L218)

- **ST-I-JP4G-H**
- **8007278**



Dimensions : 2700x45x2180
Weight : 15 Kg
Electrical connection : None
Mounting position : Wall

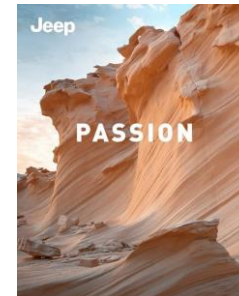

Jeep Big Visual Sales Station (H270 L218)

Requirements before installation



- The area must be accessible with a pallet truck (or equivalent).
- The wall must be reinforced according to the weight specification of the article.

to observe

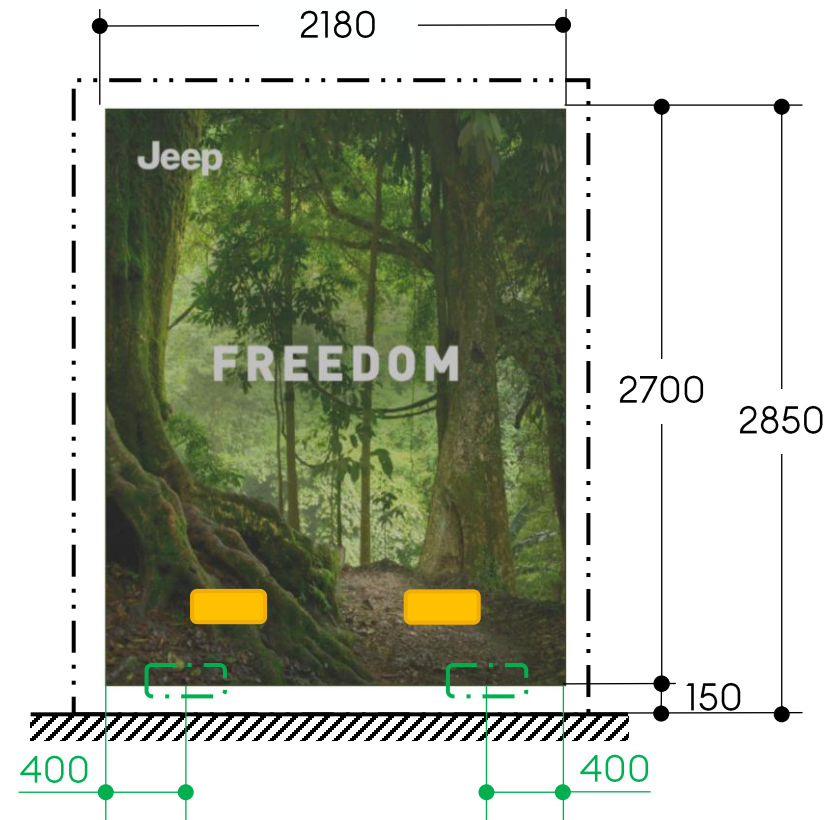
- The wall and the substructure must be made of a suitable material to support the unit.
- Supply cable, power strip etc. are not included in the scope of delivery.

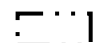

Explanation of symbols

-  Wall reinforcement
-  Inspection panel / power supply
-  Wall socket (2 options)

Sales Lamp

- **ST-I-JP04D**
- **0202714**

Dimensions : 1955x36x65

Weight : 4 Kg

Electrical connection : 230V

Mounting position : Ceiling



Sales Lamp

Requirements before installation

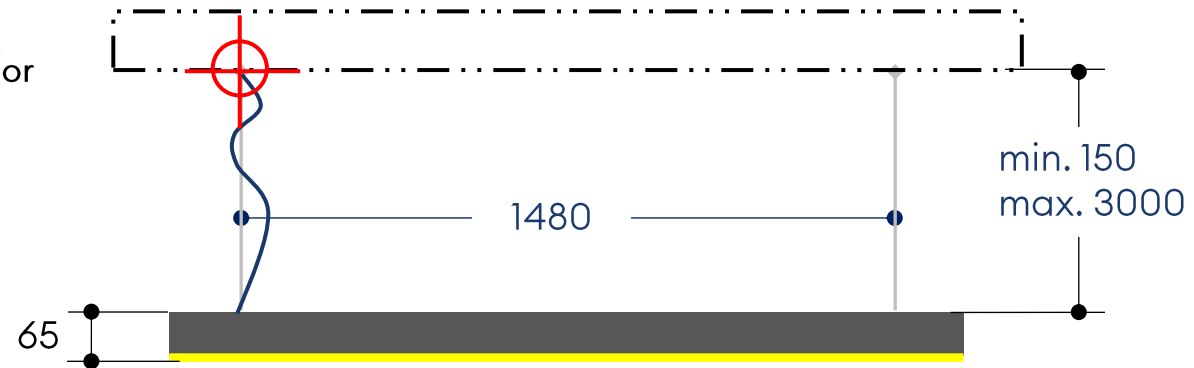

- The area must be accessible with a pallet truck (or equivalent)
- The ceiling must be reinforced according to the weight specification of the article.



to observe

- The ceiling and the substructure must be made of a suitable material to support the unit.

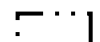
Explanation of symbols

-  Ceiling reinforcement
-  Ceiling fixing points
-  Electrical connection: Country-specific

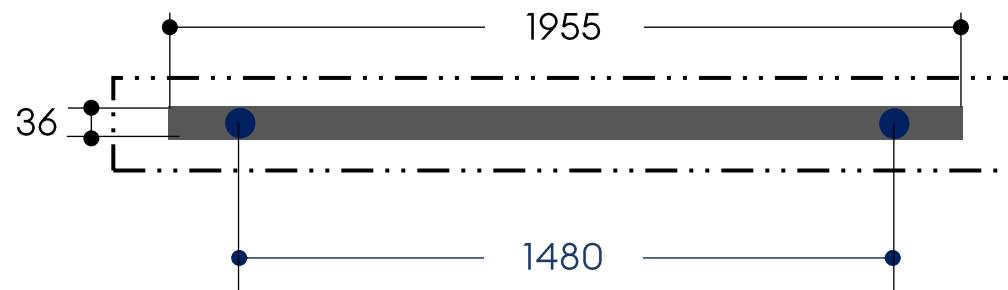

Coffee Console

- **ST-I-JP05D**
- **8005583**



Dimensions : : 1080x450x950

Weight : 70 Kg

Electrical connection : None

Mounting position : Wall/Middle space

Coffee Console

Requirements before installation

- The area must be accessible with a pallet truck (or equivalent)

to observe

- The furniture can be placed against the wall or in the middle of the room
- Supply cable, power strip etc. are not included in the scope of delivery.

Explanation of symbols

 Inspection panel / power supply

 Wall / floor socket

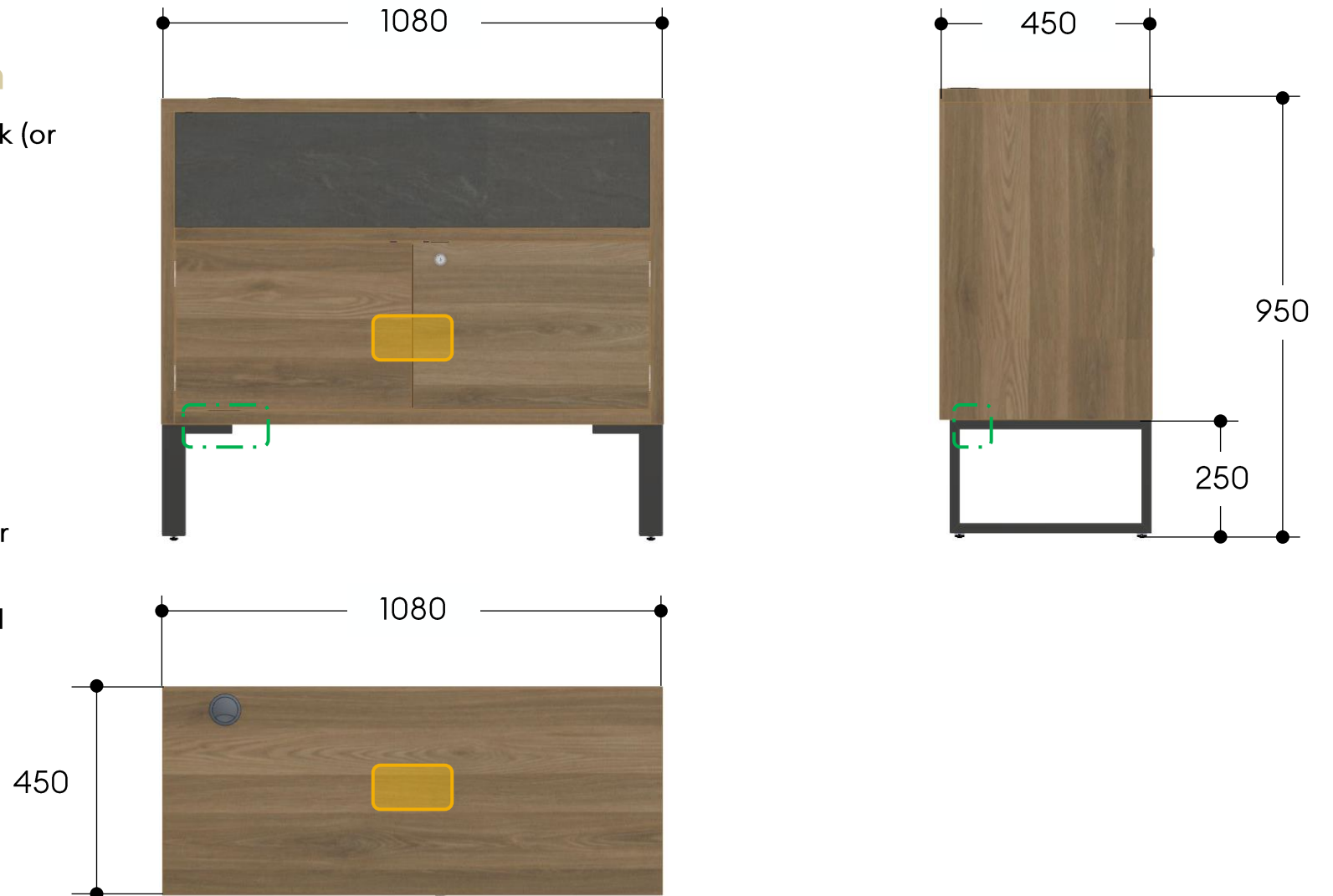

Jeep World Map Kit

- ST-I-JP05J1
- 8010991

Dimensions : 3200x45x3000

Weight : 170 Kg

Electrical connection : None

Mounting position : Wall

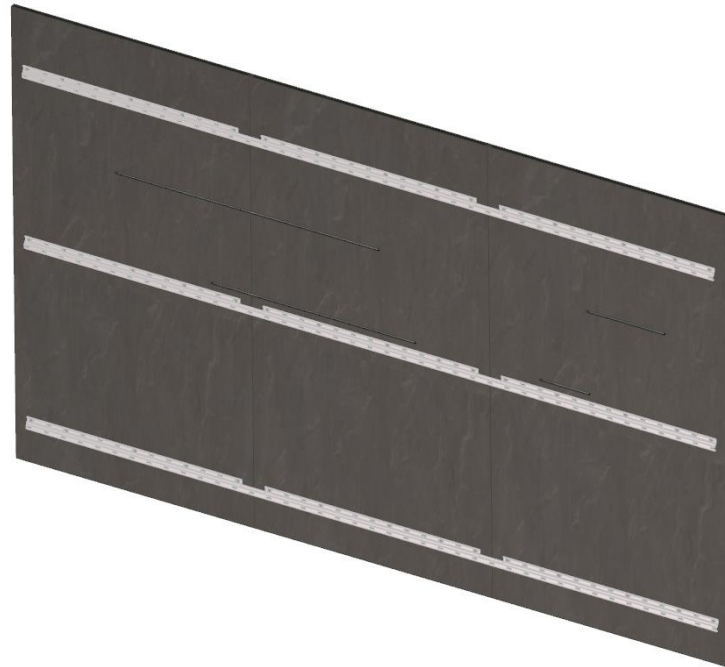

Jeep World Map Kit

Requirements before installation

- The area must be accessible with a pallet truck (or equivalent).
- The wall must be reinforced according to the weight specification of the article.

to observe

- The wall and the substructure must be made of a suitable material to support the unit.

Explanation of symbols

 Wall reinforcement

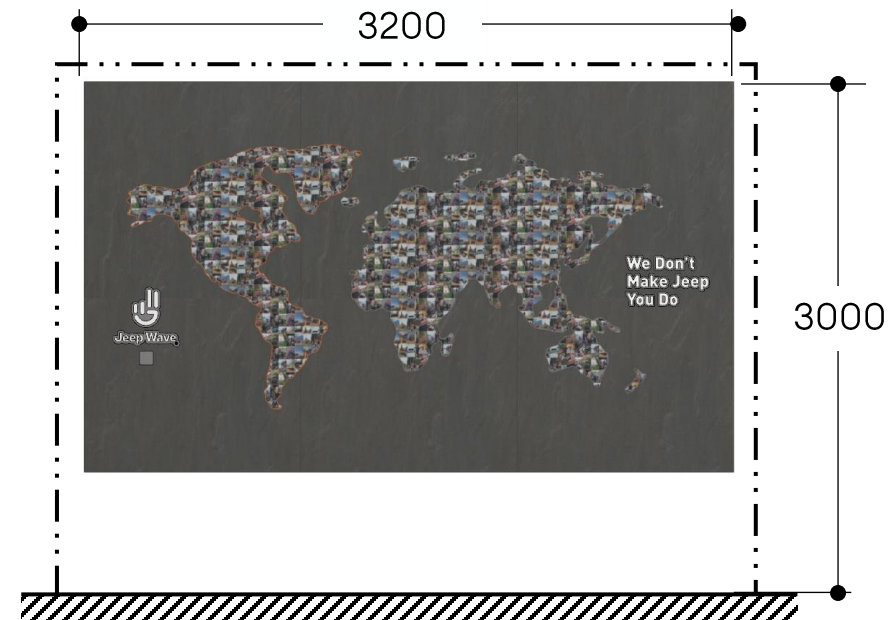
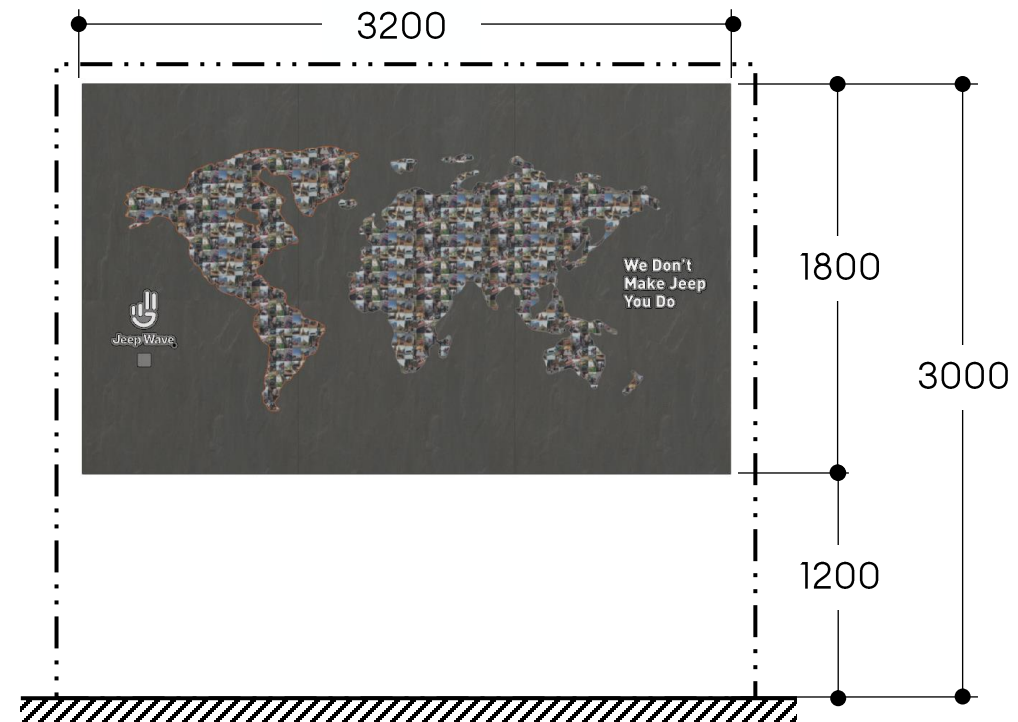

Lounge Cupboard Stone Panel Large

- **ST-I-JP TBC**
- **8006204**

Dimensions : 1600x30x3000
Weight : 80 Kg
Electrical connection : None
Mounting position : Wall

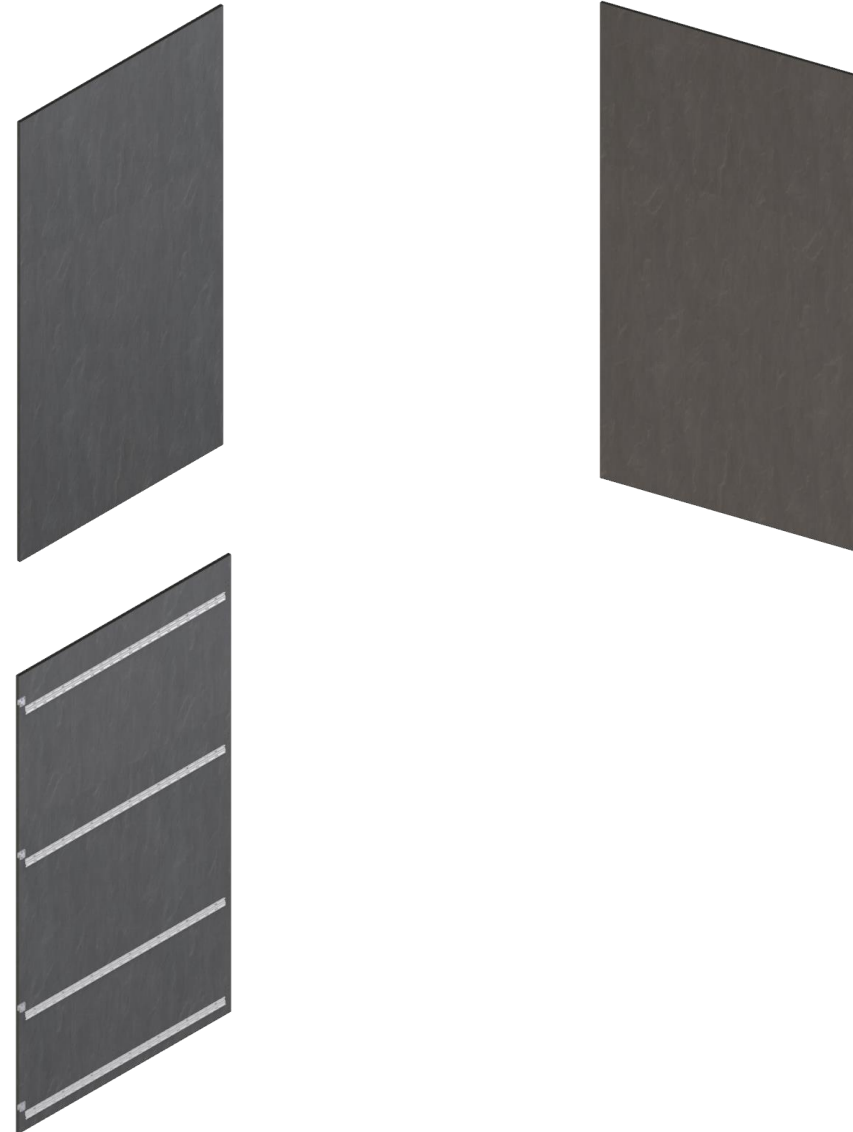

Lounge Cupboard Stone Panel Large

Requirements before installation

- The area must be accessible with a pallet truck (or equivalent).
- The wall must be reinforced according to the weight specification of the article.

to observe

- The wall and the substructure must be made of a suitable material to support the unit.

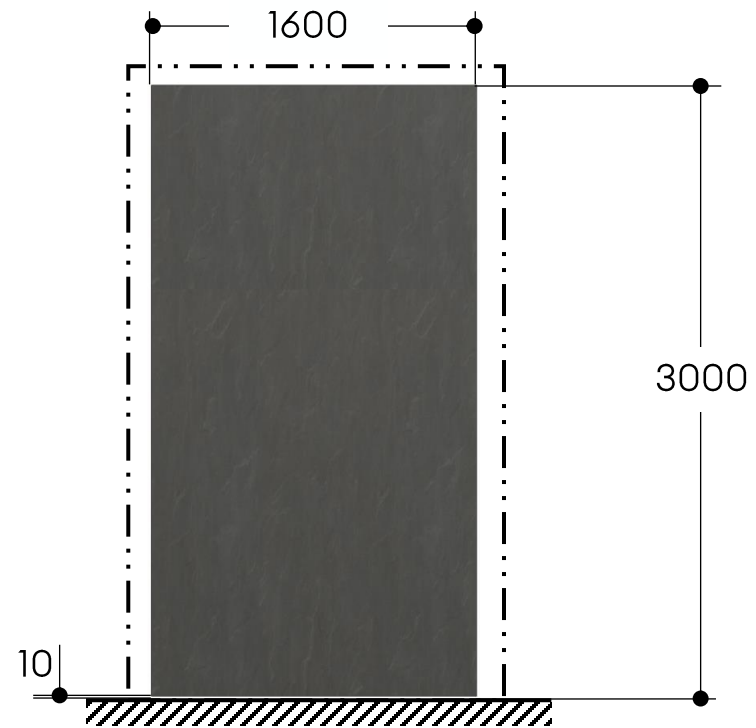

Explanation of symbols

 Wall reinforcement

Lounge Cupboard Stone Panel Slim

- **ST-I-JP TBC**
- **8006211**

Dimensions : 800x30x3000
Weight : 40 Kg
Electrical connection : None
Mounting position : Wall



Lounge Cupboard Stone Panel Slim

Requirements before installation

- The area must be accessible with a pallet truck (or equivalent).
- The wall must be reinforced according to the weight specification of the article.

to observe

- The wall and the substructure must be made of a suitable material to support the unit.

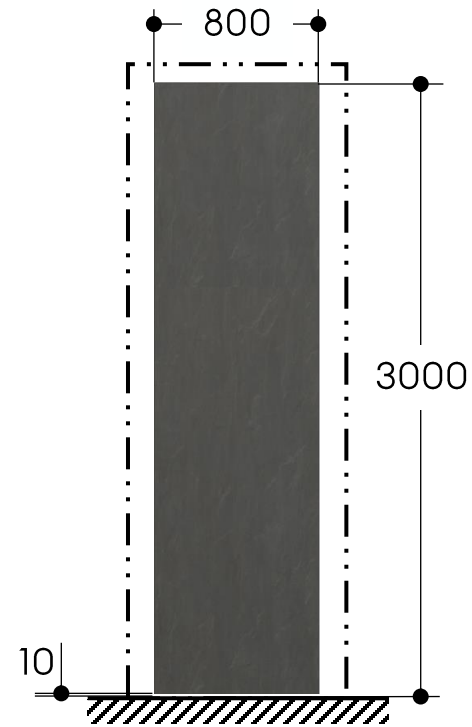

Explanation of symbols

 Wall reinforcement

Lounge Cupboard

- **ST-I-JP TBC**
- **8006213**



Dimensions : 1600x400x980

Weight : 95 Kg

Electrical connection : None

Mounting position : Wall/Middle space

Lounge Cupboard

Requirements before installation

- The area must be accessible with a pallet truck (or equivalent).

to observe

- The Lounge Cupboard is mounted in conjunction with the Jeep World Map Kit and/or with the Lounge Cupboard Stone Panel Large / Slim.
- Supply cable, power strip etc. are not included in the scope of delivery.

Explanation of symbols

-  Inspection panel / power supply
-  Wall socket

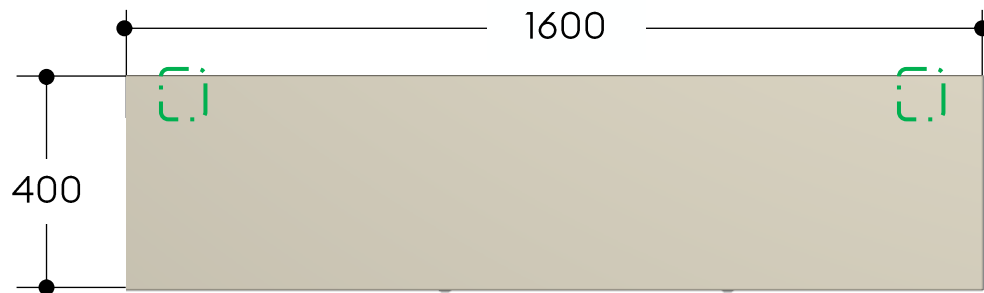
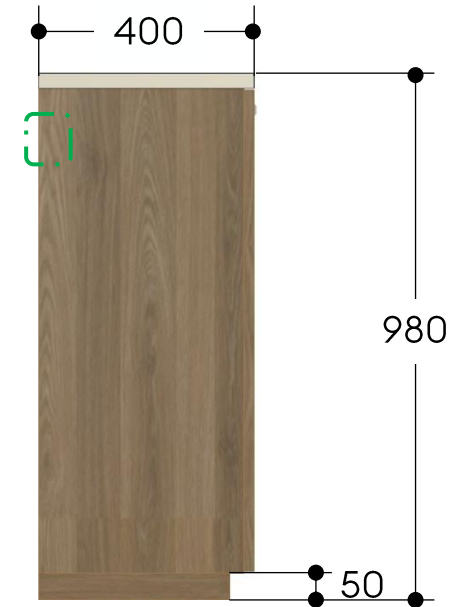
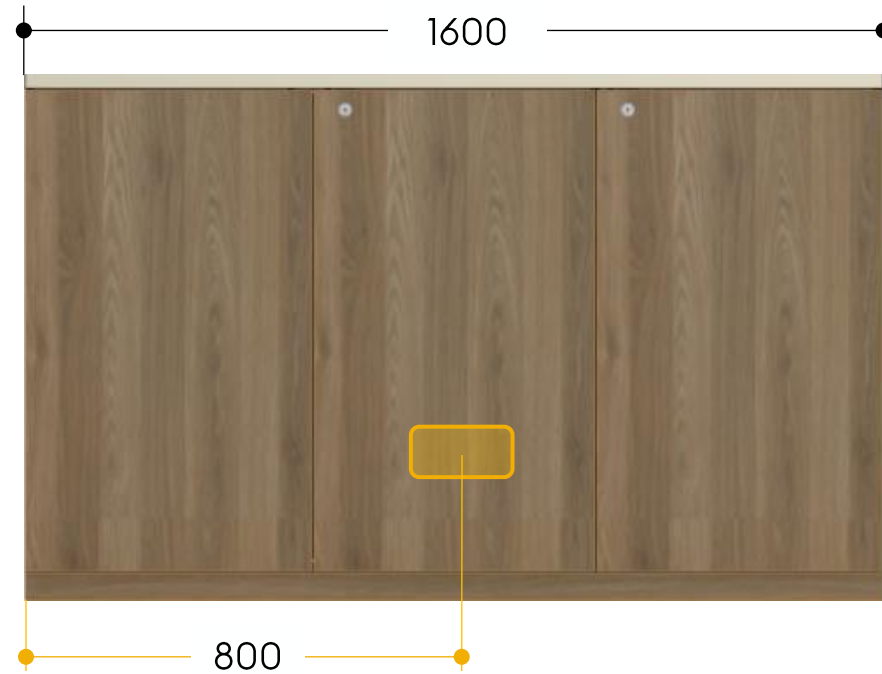

Configurator Kit Left

- **ST-I-JP06A1**
- **8005176**
- **8011320 - no preparation for screen**

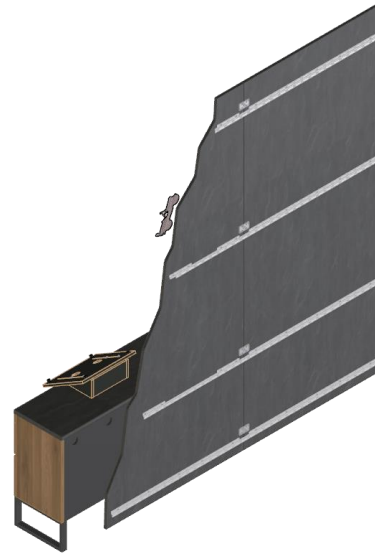

Dimensions : 3000x476x3000

Weight : 290 Kg

Electrical connection : None

Mounting position : Wall

Configurator Kit Left



Requirements before installation

- The area must be accessible with a pallet truck (or equivalent).
- The wall must be reinforced according to the weight specification of the article.

to observe

- Supply cable, power strip etc. are not included in the scope of delivery.
- Monitor and monitor holder are not included in the scope of delivery.
- The wall and the substructure must be made of a suitable material to support the unit.

Explanation of symbols

-  Wall reinforcement
-  Inspection panel / power supply
-  Wall socket

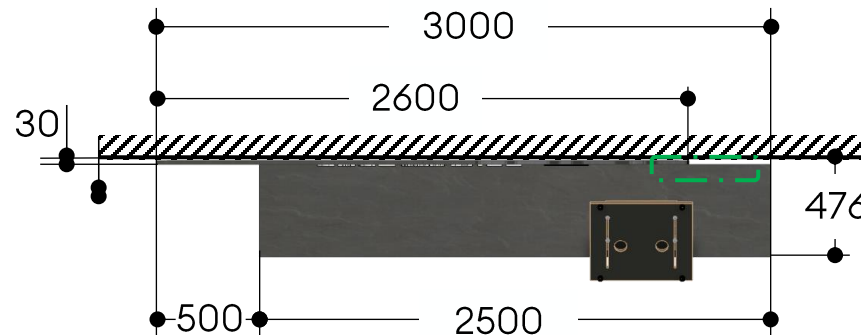
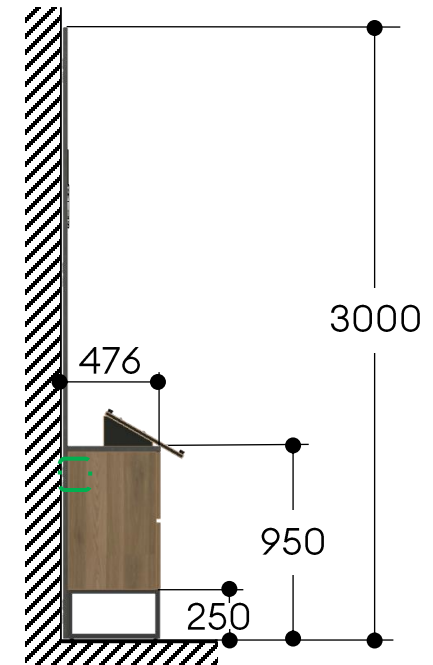
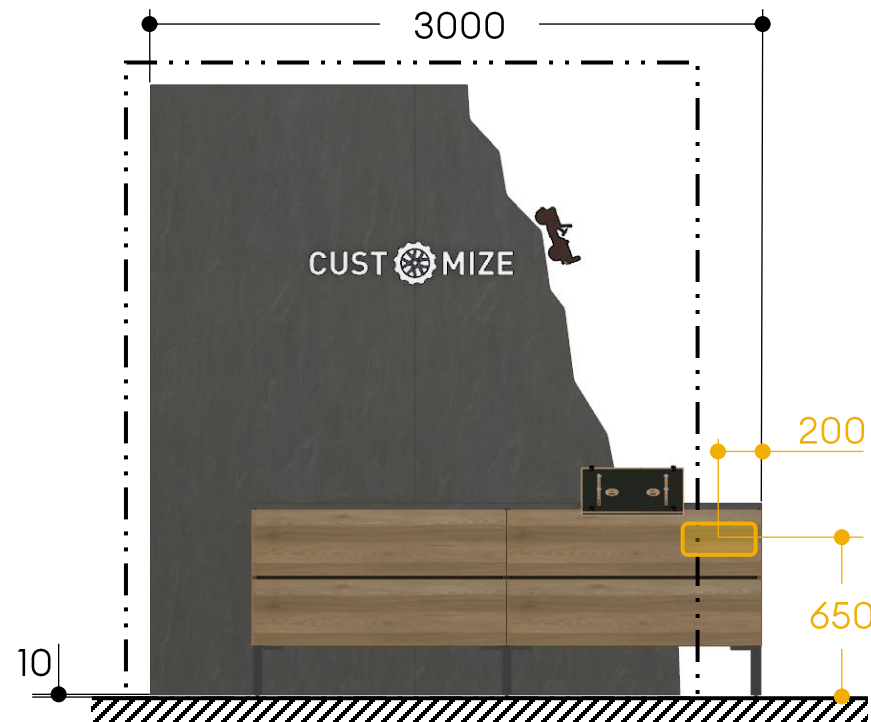

Configurator Kit Right

- ST-I-JPB1
- 8008302
- 8011321 - no preparation for screen

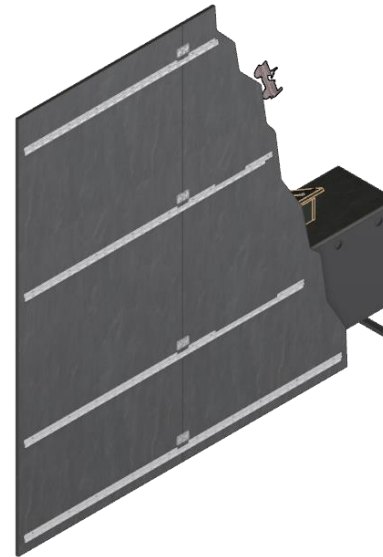

Dimensions : 3000x476x3000

Weight : 290 Kg

Electrical connection : None

Mounting position : Wall

Configurator Kit Right



Requirements before installation

- The area must be accessible with a pallet truck (or equivalent).
- The wall must be reinforced according to the weight specification of the article.

to observe

- Supply cable, power strip etc. are not included in the scope of delivery.
- Monitor and monitor holder are not included in the scope of delivery.
- The wall and the substructure must be made of a suitable material to support the unit.

Explanation of symbols

-  Wall reinforcement
-  Inspection panel / power supply
-  Wall socket

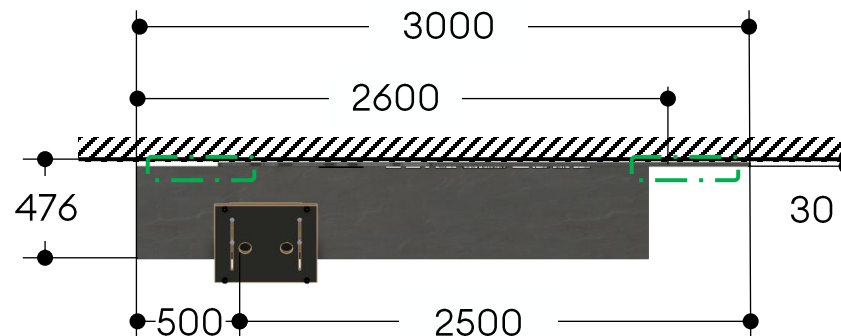
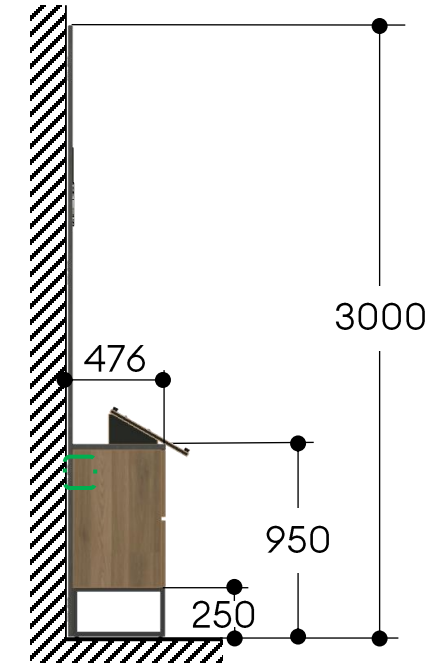
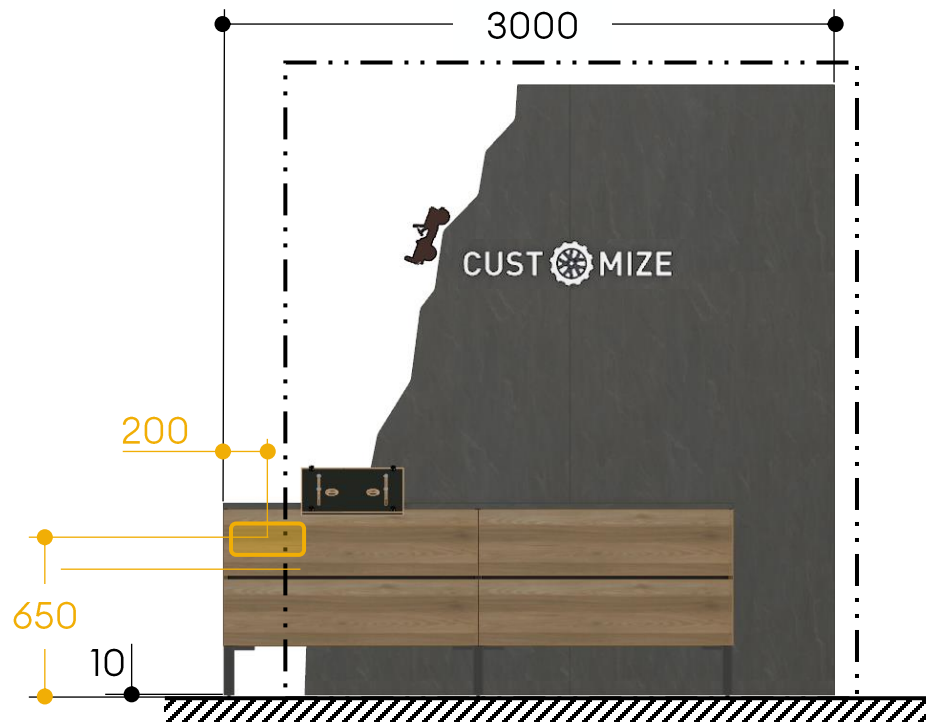

Merchandising Wall

- ST-I-JP07A
- 8011098

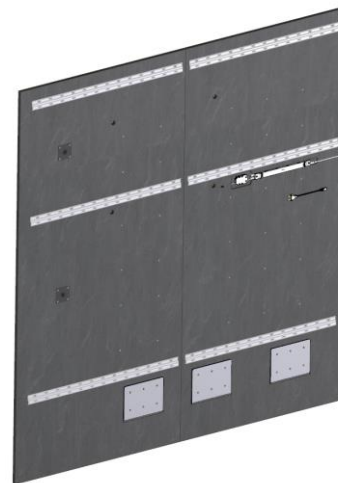
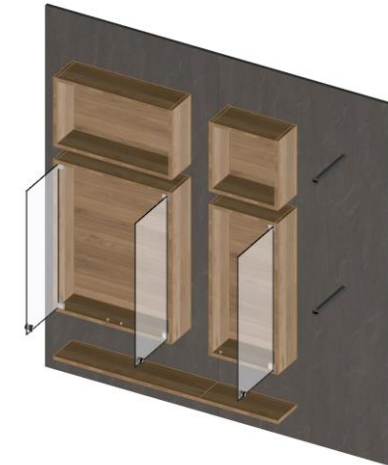

Dimensions : 2100x410x2500
Weight : 225 Kg
Electrical connection : 230V
Mounting position : Wall

Merchandising Wall

Requirements before installation



- The area must be accessible with a pallet truck (or equivalent).
- The wall must be reinforced according to the weight specification of the article.

to observe

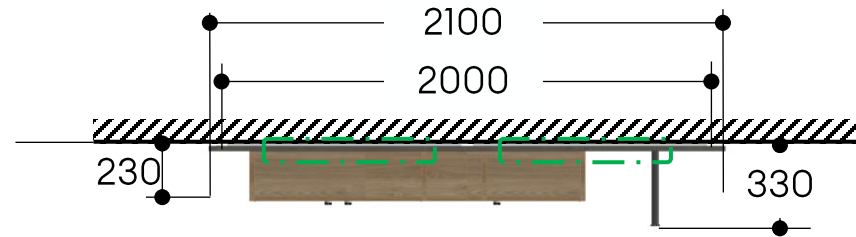
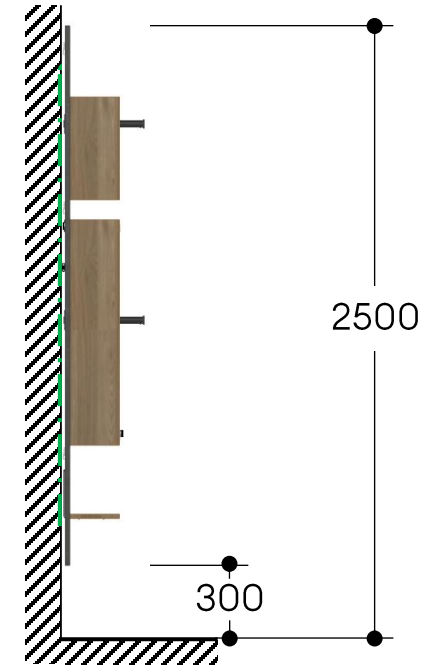
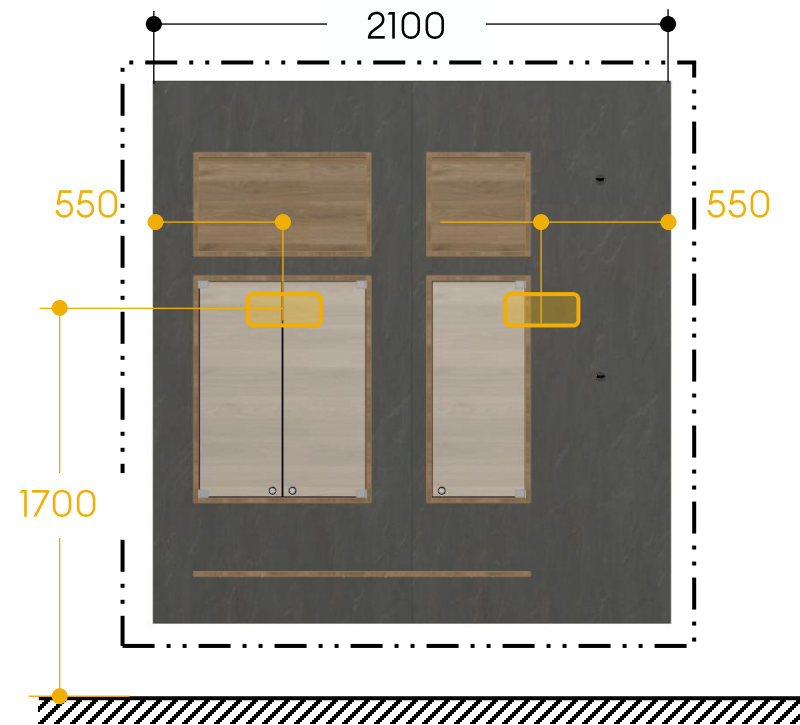
- Supply cable, power strip etc. are not included in the scope of delivery.
- The wall and the substructure must be made of a suitable material to support the unit.

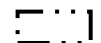

Explanation of symbols

-  Wall reinforcement
-  Inspection panel / power supply
-  Wall socket

Merchandising Monitor Console

- ST-I-JP07C
- 8005599



Dimensions : 1600x450x950

Weight : 80 Kg

Electrical connection : 230V

Mounting position : Wall/Middle space

Merchandising Monitor Console

Requirements before installation

- The area must be accessible with a pallet truck (or equivalent).

to observe

- The furniture can be placed against the wall or in the middle of the room
- Supply cable, power strip etc. are not included in the scope of delivery.
- Monitor and monitor holder are not included in the scope of delivery.

Explanation of symbols

-  Inspection panel / power supply
-  Wall / floor socket

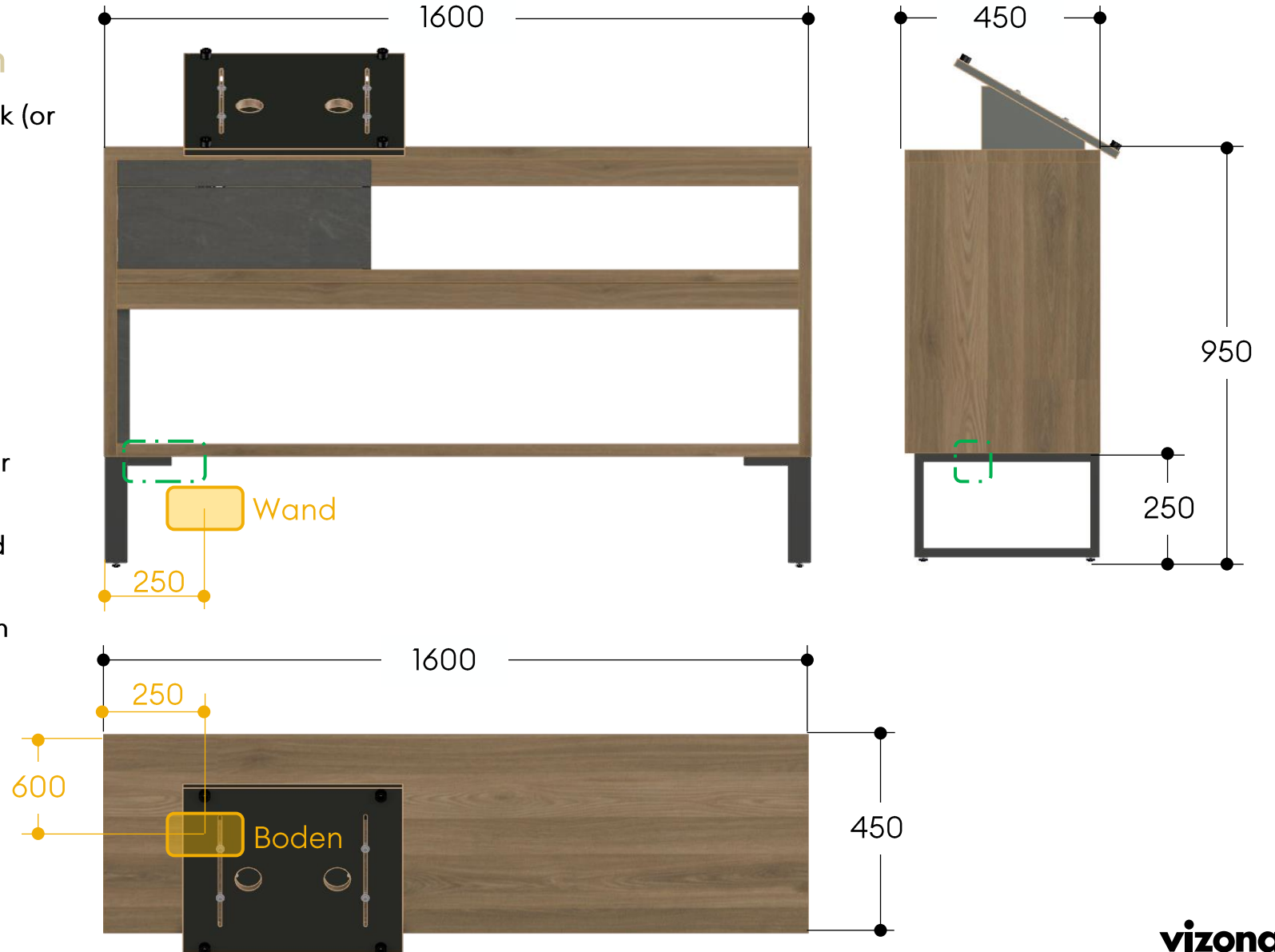

4xe Delivery Panel

- **ST-I-JP TBC**
- **8005946**

Dimensions : 1380x35x2800
Weight : 90 Kg
Electrical connection : None
Mounting position : Wall

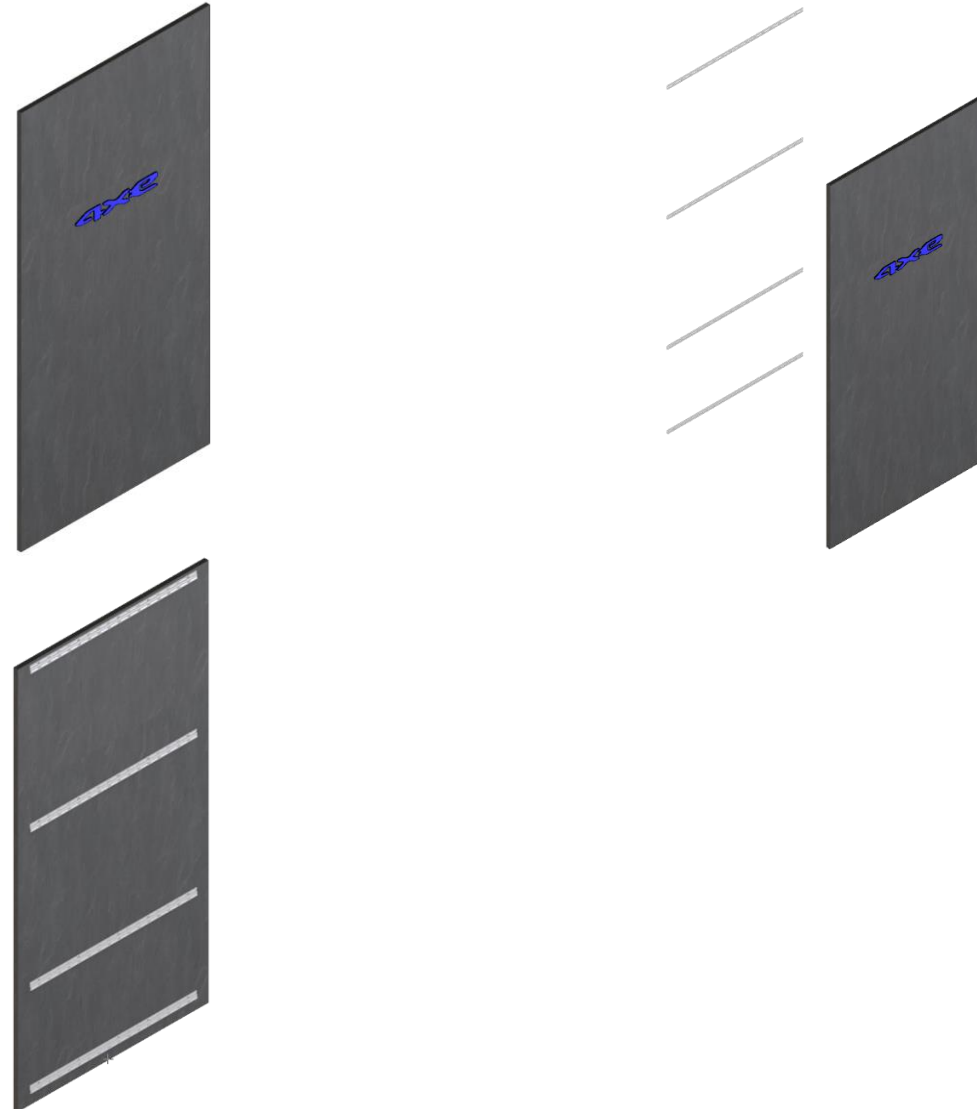

4xe Delivery Panel

Requirements before installation

- The area must be accessible with a pallet truck (or equivalent).
- The wall must be reinforced according to the weight specification of the article.

to observe

- The wall and the substructure must be made of a suitable material to support the unit.

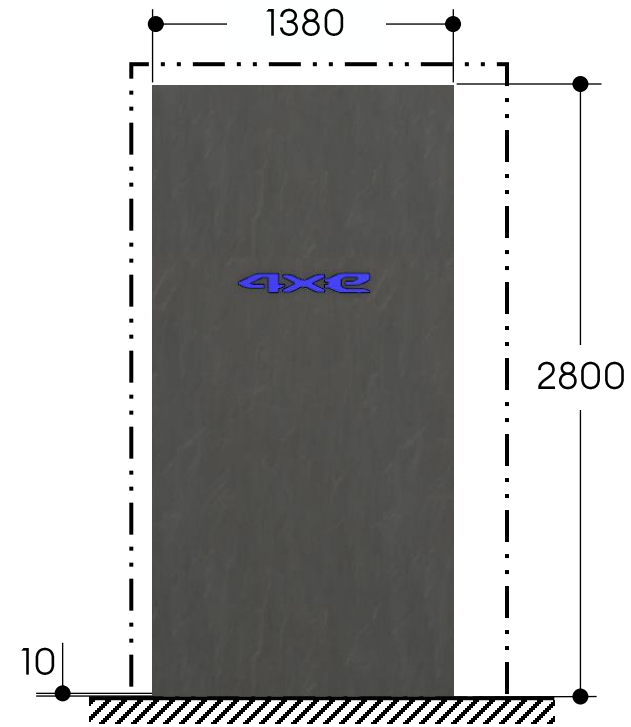

Explanation of symbols

 Wall reinforcement

“

Thank you